

ALVA

SHORT STAND CERAMIC LOG
HEATER WITH LAVA ROCKS

GHP48



Your world is better with Alva

- THIS IS A LOW PRESSURE APPLIANCE TO BE USED ONLY WITH A 2.8kPa SANS 1237 APPROVED REGULATOR AND SANS 1156-2 HOSE (REGULATOR AND HOSE FITTED AND SUPPLIED)
- FOR YOUR OWN SAFETY, PLEASE READ THIS MANUAL CAREFULLY AND ALWAYS OPERATE THIS PRODUCT ACCORDING TO THE INSTRUCTIONS
- IT IS ILLEGAL AND DANGEROUS TO CHANGE OR MODIFY ANY PART OF THIS APPLIANCE

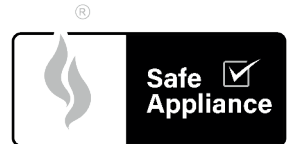

APPROVED FOR USE IN
SOUTH AFRICA

Manufactured for and distributed by: **ALVA** A division of Stingray Accessory Manufacturers (Pty) Ltd | P.O. Box 30014, Tokai, 7966 | +27 21 442 1540
info@stingray.co.za | www.alva.co.za | TOLL-FREE NUMBER: 086 100 ALVA (2582)

 /AlvaGas

 /alvagas

IMPORTANT SAFETY INFORMATION

As with all appliances, misuse of this appliance or failure to fully follow these instructions may cause fire, injury or death.

Please read all the instructions before using your gas patio heater.

- The operator must understand all safety requirements as detailed in this manual before using the unit.
- THIS UNIT MUST BE THOROUGHLY CHECKED BEFORE USE.
- Ensure that all the gas fittings are correctly and firmly fitted before every use.
- Remove all packaging materials before assembling.
- For OUTDOOR USE ONLY.
- The use of this appliance in enclosed areas can be dangerous and is PROHIBITED.
- Not for commercial use.
- For use with LP Gas only.
- DO NOT use within 1m of any flammable surfaces.
- DO NOT use this patio heater if you do not clearly understand the instructions and/or how to operate the controls.
- Phone the customer care line at 086 100 ALVA (2582) or email customercare@stingray.co.za for assistance.
- DO NOT store flammable materials or another gas cylinder near the patio heater.
- DO NOT leave the patio heater unattended while in use.
- Ensure that the gas supply is turned OFF at the gas cylinder after use and while the patio heater is unattended.
- DO NOT move the patio heater while in use.
- DO NOT place objects on or against the patio heater.
- DO NOT use a naked flame to test for leak. Follow the Leak Testing procedure outlined under "LEAK TEST" in this manual.
- Leak test the patio heater every year or if you ever smell gas.
- NEVER use this patio heater with a cylinder other than the size recommended.
- DO NOT unscrew the regulator while the patio heater is on or if the gas cylinder valve is open.
- DO NOT use a patio heater you suspect is faulty.
- For safety reasons, only a qualified technician may execute maintenance and repairs.
- The warranty for the patio heater will be rendered void if the appliance is serviced or repaired by anyone other than an Alva appointed technician.
- The patio heater should be inspected once a year by a qualified technician, to make sure the unit is safe and fault free.



Please read the instructions carefully before use.

Retain this manual for future reference.

- DO NOT use in windy or gusty conditions.
- Accessible parts may get very hot during operation. Keep young children at a safe distance.
- Clean with warm soapy water only after the patio heater has cooled down.
- Keep the burner unit clear of spider webs or other obstructions.
- Close the gas cylinder valve off after use.
- Any modification of this fire pit is dangerous.
- If you smell gas close the cylinder valve immediately and check for leaks.
- Any guard or other protective device removed for servicing the heater must be replaced before operating the patio heater.

CAUTION: In case the glass surface breaks:

Shut immediately off all burners and any electrical heating element and isolate the appliance from the power supply,

- Do not touch the appliance surface.
- Do not use the appliance.

INDEX

WARRANTY	2
GENERAL INFORMATION	2
PARTS DIAGRAM	3
METHOD OF ASSEMBLY	3
FIRE PIT SET UP	4
SAFE APPLIANCE LOCATIONS	7
LEAK TEST	8
OPERATION INSTRUCTIONS	9
FLASHBACK	10
CHANGING YOUR CYLINDER	11
MAINTENANCE	11
SPECIFICATIONS	12
FREQUENTLY ASKED QUESTIONS	13
TROUBLESHOOTING GUIDE	14
AFTER SALES SERVICE	15

KEY



Important information.



Cautions and warnings.



Danger.



Contact an approved ALVA technician.



Do It Yourself.

WARRANTY

PLEASE RETAIN YOUR PROOF OF PURCHASE FOR WARRANTY CLAIMS.

ALVA warrants this appliance to be free of defects in material and quality for a period of 12 months from date of original purchase. This warranty covers the intended use of this appliance – within a domestic setting and not for commercial or industrial purposes. Any damage caused by wilful abuse, tampering, modification or unauthorized repair will not be warranted.

Please retain all packaging material, as items returned without original packaging material may be subject to a withholding fee. Where this appliance is found to be defective, damaged, broken, or does not work correctly for the intended purpose, you must return the appliance to the retailer from where it was purchased. The warranty will only be effected with valid proof of purchase. Failure to provide the proof of purchase will most likely result in the repair or service required being chargeable.

If you have any questions while setting up or using this patio heater please visit www.alva.co.za or call 086 100 2582 (ALVA) or e-mail customer@stingray.co.za

GENERAL INFORMATION

Before using this patio heater, please read through this manual and make sure you understand everything. If you are not sure, call 086 100 ALVA (2582) or visit www.alva.co.za for help.

This patio heater is a safe and efficient form of heating when used according to these instructions.

Reading and understanding this manual should give you a good indication of what to expect from your Alva patio heater.

If this product is not what you want or need, please help Alva and the environment by not damaging or destroying any part of the packaging, the manual or the Styrofoam inserts.

Always keep your proof of purchase. Keep these instructions for future use. If you lose this copy, you can obtain a new copy from your dealer or online at www.alva.co.za.



Thank you for your purchase of this patio heater. Please read these instructions carefully before use and keep them in a safe place for future reference.



Not using appliances according to the instructions is extremely dangerous and can lead to property damage, injury or death.



For outdoor use only.

For use with LPG only.

*DO NOT use within 1m of **any flammable** surfaces.*

Always turn OFF the gas supply at the cylinder after use.

DO NOT store flammable materials or another cylinder near the heater.

PARTS DIAGRAM

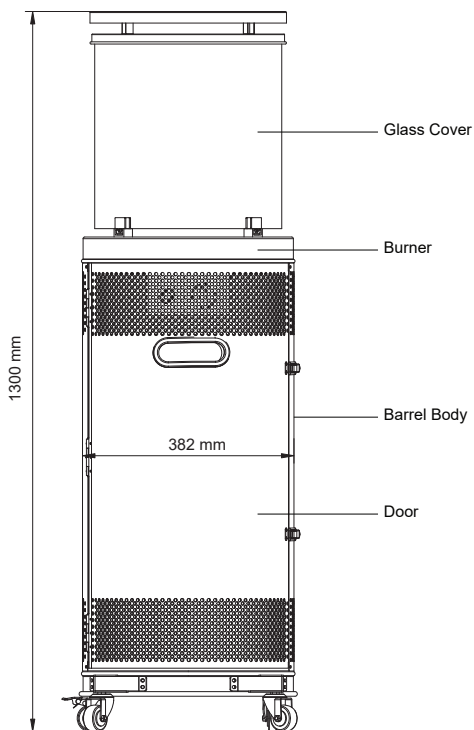

METHOD OF ASSEMBLY

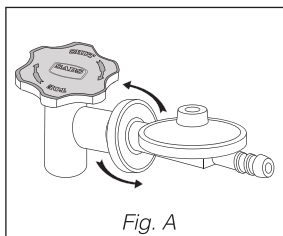

Fig. A

9kg ALVA cylinder recommended with a 5/8" BSP thread; horizontal exit valve. The Bullnose Regulator tightens to the left hand side (anti-clockwise) (Fig. A).

If you have bought a new gas cylinder, the cylinder needs to be purged (cleared out), before its first use. If it is not purged of air,

the fire pit will not work properly. This should happen at the gas filling station when you fill up the cylinder. Always check this with your gas supplier.

WARNING:

This patio heater operates directly on an ALVA 9kg industrial cylinder with a 5/8" HORIZONTAL exit valve. It is NOT to be used on a domestic cylinder with a 3/8" VERTICAL exit valve.

FIRE PIT SETUP

1. Before removing this patio heater from the packaging, read this manual in full and make sure that it is what you want/need.
2. Remove the patio heater from packaging.

EXPLODED VIEW

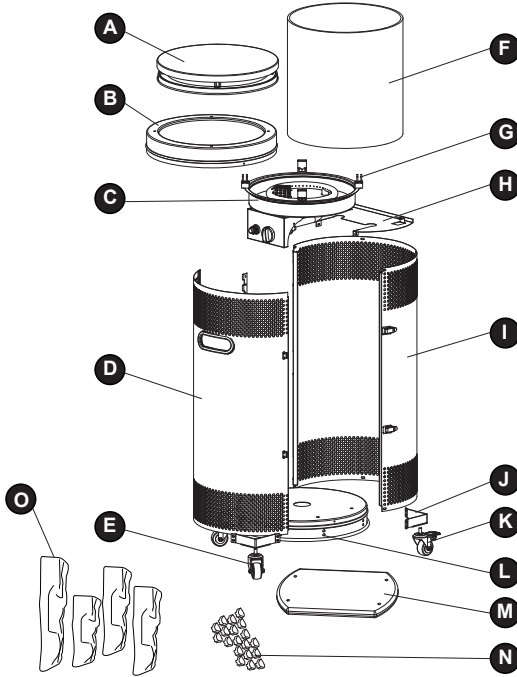

PART	DESCRIPTION	QUANTITY
A	Reflector	1
B	Barrel lid	1
C	Burner Assembly	1
D	The left door	1
E	Wheels(w/o Brake)	2
F	Glass	1
G	Glass Bracket	4
H	Anti-scald plate	1
I	Barrel body	1
J	Wheels Bracket	1
K	Wheels(with Brake)	2
L	Bottom of the barrel	1
M	Steady Box	1
N	Lava Rocks (One Pack)	1
O	Ceramic Logs	4

TOOLS NEEDED

- Philips screwdriver with medium blade.
- Spray bottle of soap solution for leak test.

ASSEMBLY PARTS

AA



M5
Flange
nut
Qty. 16

BB



Screw
M5X10
Qty. 16

CC



Washer
Qty. 16

DD



Spanner
Qty. 1

EE



Philips
screwdriver
Qty. 1

FF



AA Battery (1.5 V)
Qty. 1

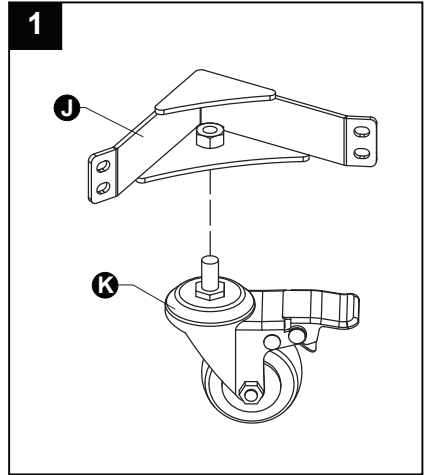

ASSEMBLY INSTRUCTIONS

1. Assemble the Wheels to wheel bracket with a spanner



2. Assemble the wheel brackets to base with M5 screws and nuts.

Hardware Used

- AA M5 Flange nut  x 16
- BB Screw M5X10  x 16
- CC Washer  x 16

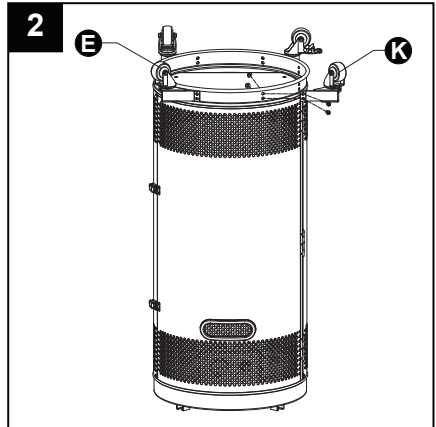

3. Secure the glass bracket into the groove of the tank cover as shown in the diagram.

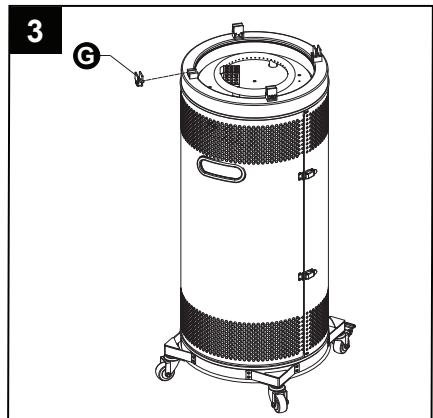

4. Place the lava rocks in the center.

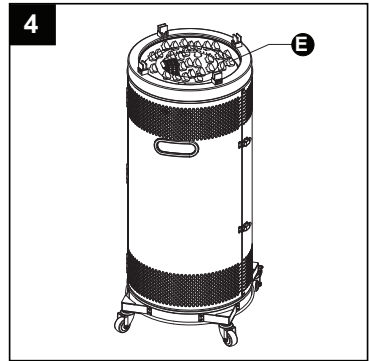

5. Put the glass into glass bracket, then tighten the screws.

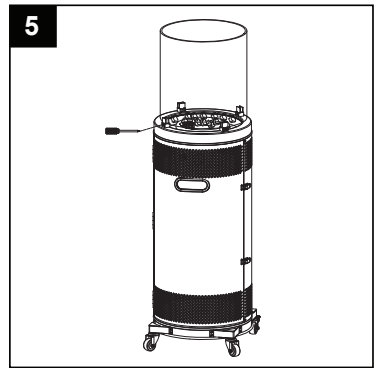

6. Add the ceramic logs.

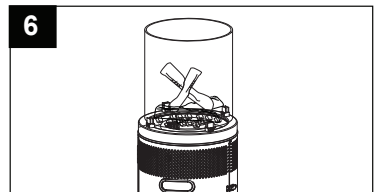

7. Put the reflector onto glass top.

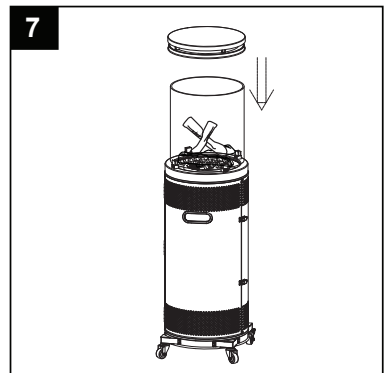

8. **⚠ WARNING!** Ensure the hose does not make contact with any high temperature surfaces, or it may melt or leak causing a fire.
- Open the gas cylinder valve and do a leak test, see page 8.
 - **DO NOT** light the fire pit when performing this leak test.
 - After passing the leak test, insert a AAA battery into battery compartment for the auto ignition to operate.

FF AA Battery (1.5 V)



Connect regulator to cylinder and tighten. Only hand tighten, do not use tools or spanners to fasten regulator to cylinder.

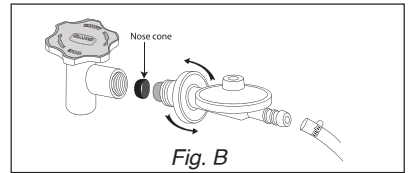
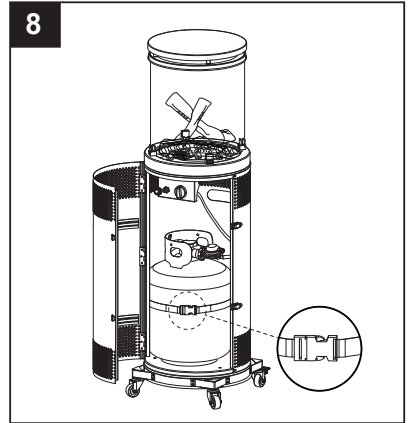

- When attaching the regulator to the cylinder check that the rubber nose cone is in place, secure and in good condition, see Fig B.

SAFE APPLIANCE LOCATIONS

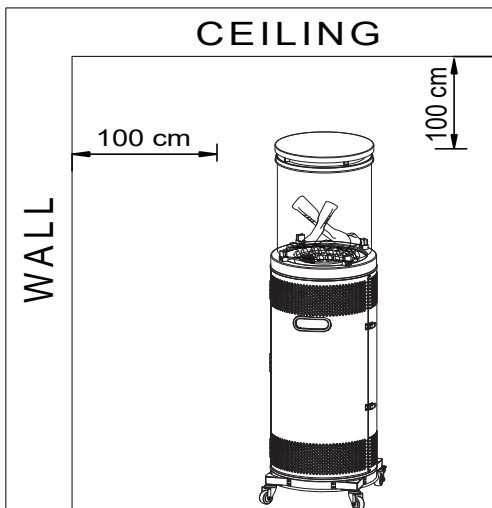

NOTE:
This appliance is for outdoor use only.

- The patio heater is for outdoor use only. Always ensure that adequate fresh air ventilation is provided.
- Always maintain proper clearance from combustible materials: 1000 mm from the Front, Rear, and Sides, and 1000 mm minimum from the ceiling.
- Always place the patio heater on level, firm ground.
- Never operate the patio heater in an explosive atmosphere, for example, in an area where gasoline or flammable liquids or vapors are stored

WARNING

- 1) For use outdoors or in amply ventilated areas.
- 2) An amply ventilated area must have a minimum of 25 % of the surface area open.
- 3) The surface area is the sum of the walls surface.

LEAK TEST

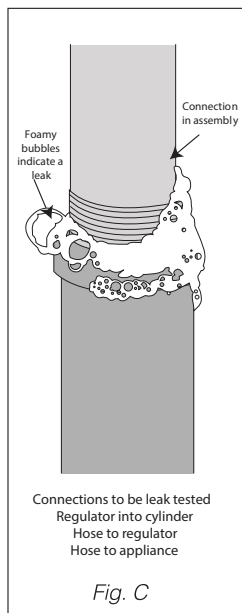

The leak test must be carried out in a well-ventilated area, free from any flames or other sources of ignition.

- With the cylinder connected to the patio heater, open the gas cylinder valve.
- Brush the connections (patio heater to cylinder) with a solution of equal parts soap and water (make sure it's foamy).
- A stream of bubbles forming indicates a gas leak. (See Fig. C)
- If bubbles appear, turn the cylinder valve OFF (clockwise) and disconnect the patio heater from the gas cylinder.
- Tighten the connection and retry the leak test.
- If you are unsure or if you cannot tighten the connection, place the cylinder outside in a cool, well-ventilated area and contact Alva on 086 100 ALVA (2582).
- A leak between the patio heater and cylinder can lead to a high-pressure fire, which is very dangerous and can result in extensive injury or even death.

How to do
a leak test



<http://www.youtube.com/watch?v=8LpZ1B0m23Y&feature=plcp>



**FOR YOUR SAFETY
IF YOU SMELL GAS**

- Turn off the gas supply at the cylinder.
- Extinguish all naked flames. DO NOT operate any electrical appliances.
- Ventilate the area.
- Check for leaks (see LEAK TEST).
- If odour persists, contact your dealer or local gas supplier immediately.

OPERATION INSTRUCTIONS

BEFORE TURNING THE GAS SUPPLY ON:

- 1.) Your patio heater was designed and approved for outdoor use only. DO NOT use it inside a building, garage or any other enclosed area.
- 2.) Make sure that the surrounding area is free of combustible materials, gasoline and any other flammable vapours or liquids.
- 3.) Ensure that there is no obstruction to air ventilation. Be sure that all gas connections are tight and there are no leaks present.
- 4.) Be sure that any components removed during assembly or servicing are replaced and fastened prior to starting.

BEFORE LIGHTING:

- 1.) Patio heater should be thoroughly inspected before each use, and be serviced by a qualified person annually. If relighting a hot patio heater, always wait at least 1 minute before doing so.
- 2.) Inspect the hose assembly for any evidence of excessive abrasion, cuts, or wear. Suspected areas should be leak tested - see page 8. If the hose leaks, it must be replaced prior to operation. Only use the replacement hose specified by the manufacturer.
- 3.) Place lava rocks in fire pan around burner as detailed in step 4 on page 6.

LIGHTING:

- 1.) Turn the control knob to the "OFF" (o) position (Fig. D).
- 2.) Open gas cylinder valve (1½ turns anti-clockwise).

NOTE: For initial start or after any cylinder change, hold Control Knob IN for 10 seconds to purge air from gas lines before proceeding.

- 3.) Press in igniter button to create sparks at the electrode and hold (Figure E).
- 4.) Press and turn burner control knob anti-clockwise to the "IGNITE/LOW" position (Figure F). Continue to press the control knob for 5 seconds after ignition.
- 5.) If ignition does not occur within 5 seconds, turn the burner control to "OFF", wait 1 minute for gas to clear and repeat the lighting procedure. If burner will still not light, refer to the Troubleshooting Section.
- 6.) Once the appliance is lit, the flame height can be changed by adjusting the burner control knob between "High" and "Low".

NOTE: If the burner fails to remain lit, all valves should be closed and a waiting period of at least 1 minute should pass before attempting to light again.

WHEN PATIO HEATER IS BURNING:

Burner will display tongues of blue and yellow flames. These flames should not produce black smoke, if so this indicates an obstruction of airflow through the burner. If excessive black smoke is detected, turn off the gas cylinder and patio heater, call 086 100 ALVA (2582) or e-mail customer care@stingray.co.za



Lighting operation should comply with the lighting instructions section. Failing to do this will cause serious injury or explosion.



Warning: DO NOT TOUCH GLASS FLAME PROTECTOR when it is working or 30 minutes after switching off the patio heater

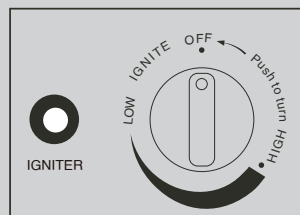

FIGURE D

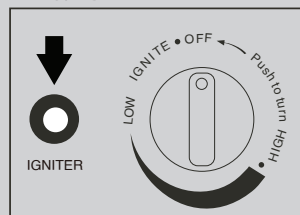

FIGURE E

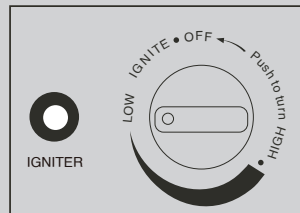
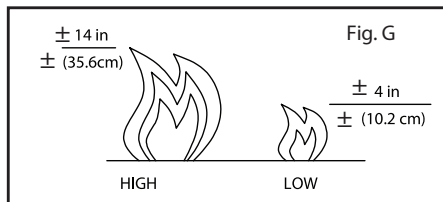

FIGURE F

Always check burner flames periodically to ensure proper operation. Flames should be mostly yellow with some blue for the best performance.

When the patio heater is ON, the normal flame from High to Low is similar to the below image. (Fig.G)



NOTE:

DO NOT COVER THE BURNER AND LAVA ROCKS UNLESS THE FIRE IS OUT AND COMPLETELY COOLED DOWN.

RE-LIGHTING:

- 1.) Turn control knob "OFF" (o).
- 2.) Repeat the "Lighting" step on page 9.
- 3.) When relighting a hot patio heater, always wait at least 1 minute before doing so.

TURNING OFF THE BURNER:

- 1.) Make sure the control knob is in the "OFF" (o) position and wait 30 minutes until the appliance is cool.
- 2.) Turn the cylinder valve off, then disconnect the hose and regulator from the cylinder.
- 3.) Store the cylinder in a safe and secure location.

FLASHBACK (flames in the burner tube)

If a flashback occurs (indicated by a roaring noise), immediately close off the cylinder valve.

- Turn the patio heater OFF at the control knob.
- Disconnect the regulator and allow the patio heater to cool.
- Check for blockages in the burner head. Clean with compressed air, a small, soft brush or pipe cleaners.
- If the problem persists in reuse, have the patio heater checked by a qualified technician.



FOR YOUR SAFETY

Be careful when attempting to manually ignite this patio heater. Holding in the control knob for more than 10 seconds before igniting the gas - will cause a ball of flame upon ignition.



FOR YOUR SAFETY

Patio heater will be hot after use. Handle with extreme care.



BEFORE REMOVING THE BURNER:

All the burner lava rocks must be removed from Patio heater and the steel the steel plate cleaned of debris and dust.

CHANGING YOUR CYLINDER

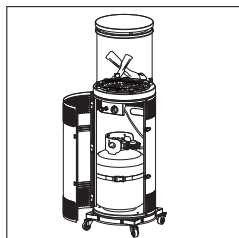

Fig. H

(by turning it clockwise). Allow the fire pit

Make sure the cylinder valve is closed (by turning it clockwise). Allow the patio heater to fully cool before replacing the cylinder. Open the patio heater door to expose the cylinder, allowing you to access and replace the cylinder (as seen on Fig. H)

Remove and replace the cylinder. ALWAYS check that the regulator sealing washer (nose cone) is intact and in place before reattaching the regulator to a cylinder. (FIG. B, Page 6)

- Perform the leak test as detailed on page 8 every time you replace the gas cylinder.
- DO NOT attempt to remove the regulator while the patio heater is on or if the cylinder valve is not closed.

MAINTENANCE

- Always make sure the patio heater is OFF and cool, with the cylinder valve closed, before conducting any maintenance.
- Your patio heater should be checked once a year by a qualified technician.
- If faults are suspected or detected, stop using the patio heater and contact ALVA.
- Clean the exterior and storage area of your patio heater when required to remove dust.
- DO NOT use abrasive products to clean the patio heater; these may damage the paint work.
- Check the burner and remove any debris, dirt, spider webs or wasp nests from the burner ports by using compressed air or a pipe cleaner. DO NOT clean the burner with water or tamper with the jets. If a jet is blocked it must be replaced with an original manufacturer marked jet.
- Replace parts and allow the patio heater to dry properly before storing.
- If the gas control or ignitor is exposed to water or gets wet, dry it properly before attempting to light the patio heater. You might have to replace the parts if the patio heater does not ignite.
- The airflow must not be obstructed. Keep the controls and burner passage clean.



WARNING:

Never attempt to remove the regulator if the fire pit is on or if the cylinder valve is not properly closed.

Clean fire pit and lava rocks with a soft brush or blow clean with compressed air. If any part of the patio heater is in need of replacing, use only original Alva parts. Using any other spare parts is dangerous and will void the warranty

When the patio heater is not in use for extended periods, always keep the burner head covered.

Your patio heater should be checked once a year by a qualified technician. Take special care to retighten any fixtures or nuts and bolts that have come loose

Signs of a blockage:

1. Gas odour with black smoke.
2. Patio heater making popping sounds.
3. Patio heater "Flashes back" in burner tube.

Storage

Store the patio heater in a cool dry place. If in a coastal area extra care must be taken in selecting the storage area as rust will occur if exposed to the elements. Disconnect the cylinder and store separately in a protected dry and cool place. If desired, cover the patio heater to protect exterior surfaces and to help prevent dust build up in the air passages

Note: Wait until the patio heater is cool before covering

Cleaning and care

- Wipe off all surfaces with a soft, moist cloth. DO NOT clean the patio heater with combustible or corrosive cleaners.
- Remove debris from the burner to keep it clean and safe for use.
- To clean glass flame protector, we suggest using a damp cloth with soap solution or suitable glass cleaner. Rinse and dry afterwards if required.
- To clean lava rocks, we suggest using a soft brush, do not use water

SPECIFICATIONS

Model	GHP48
Type of Gas	LPG
Operating Pressure	2.8kPa
Injector Size (Main)	1.42mm
Gas Consumption	582gr/hr at Max
Heat Output	8kW

This patio heater has been tested and is LPGSA approved under specifications SANS 1539 (appliance), SANS 1237 (regulator) SANS 1156 (hose)

FREQUENTLY ASKED QUESTIONS



If you are still unable to correct the problem with the information in this guide, then you need to contract your nearest dealer or manufacturer.

Q: Why is there an odour when I use a gas fire pit?

A: All gas appliances give off an odour. This could be harmful if inhaled for extended periods of time. This "smell" is normal, and it does not mean that you have a gas leak.

The smell of raw gas (just before you ignite the appliance) differs from the smell coming from the fire pit when it is in use. The odour is added to allow easy gas detection.

Q: Why must there be ventilation when using a gas fire pit?

A: Whenever fuel (LP Gas in this case) is burned, ventilation is needed. Any fire needs oxygen to burn. Think of a fireplace, you require a chimney or flue for the smoke to exit the house. Even though a gas fire pit does not generate smoke, it still generates carbon monoxide and carbon dioxide, which can be dangerous if not diluted by fresh air. Always ensure adequate ventilation by leaving a door or window open.

Q: How long will the gas in my cylinder last?

A: This depends on how you use your fire pit. It is easy to calculate your gas consumption. Take the capacity of the gas cylinder in grams (i.e. 9000g for a 9kg cylinder) and divide it by the gas consumption of the fire pit, on your desired setting. The answer to the calculation is the approximate number of hours that your fire pit will burn for.

Q: What do I do if I have an over-filled cylinder?

A: The best method to determine if your cylinder is over-filled is to weigh it. Subtract the "tare" mass from cylinder weight – this gives you the weight of your gas. If this gas weight exceeds your cylinder design weight (9kg) then return the cylinder to your gas supplier.

TROUBLE SHOOTING GUIDE

TROUBLE	CAUSE	REMEDY
Odour	Combustion	N/A - The Combustion process will always cause an odour
Strong Odour	Incorrect gas mixture	Obtain LPG only from reputable LPG dealers
	Unburned gas leak	Perform a leak test. Always ensure there is proper ventilation
Burns then dies	Over-filled Cylinder	Return to gas supplier
	Ventilation	Make sure the room has adequate ventilation
	Empty Cylinder	Replace with a full cylinder
Fire pit does not light up	Empty cylinder	Replace with gas full cylinder
	No gas flow	Open cylinder valve
No ignition spark	Dead battery	Replace with new AAA battery
Carbon build up - Thick black smoke	Blockage in the burner	Turn control knob to OFF position let appliance cool, Remove blockage and clean burner inside and outside
Low flames or not full flame around burner	Flame spreader holes partially closed	Clean the burner

How to test if your cylinder is overfilled



<http://www.youtube.com/watch?v=Ya-vsYE8nzCw&feature=plcp>



Should you experience problems with this gas fire pit, carry out the necessary checks as per Trouble Shooting Guide.

If you are still unable to correct the problem with the information in this guide, then you need to contact your nearest dealer or manufacturer

AFTER SALES SERVICE

MANUFACTURED FOR AND DISTRIBUTED BY ALVA,
A division of Stingray Accessory Manufacturers (Pty) Ltd
P.O. Box 30014
Tokai, 7966
Tel: 021 442 1540
E-mail: customercare@stingray.co.za
www.alva.co.za
@ /alvagas
f www.facebook.com/AlvaGas

TOLL FREE NUMBER **086 100 ALVA (2582)**